

# C311C

## NAPA COUNTER CHAIR

BOX INCLUDES:

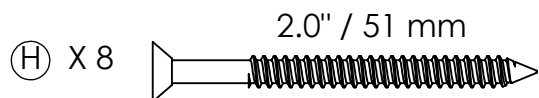
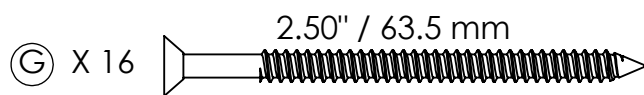
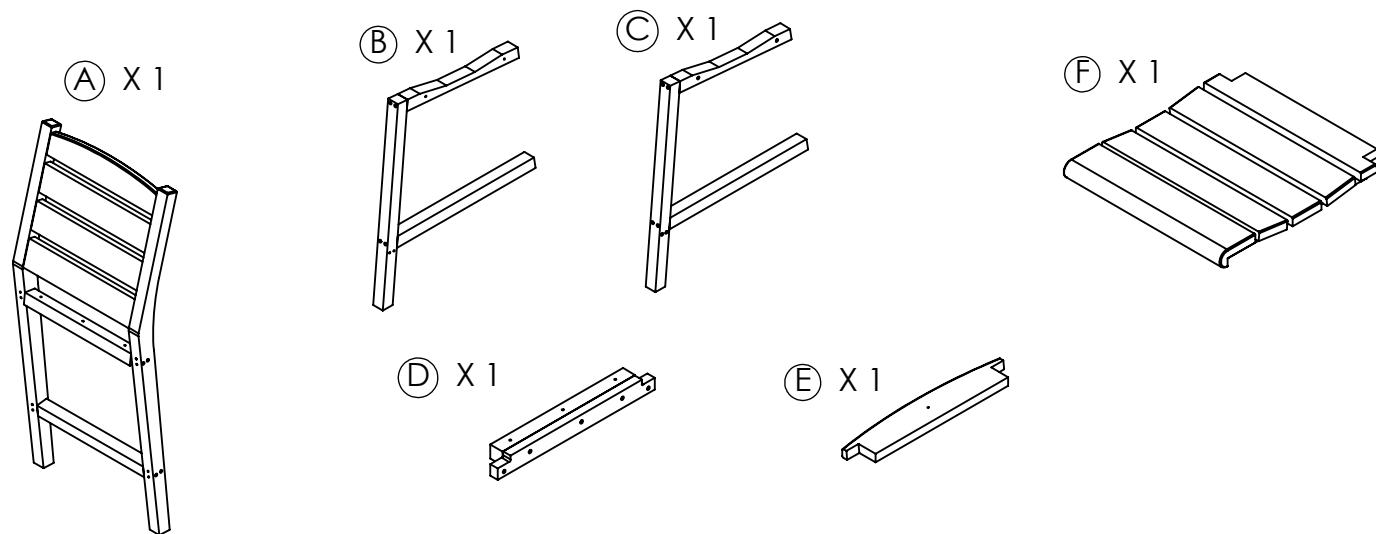

FASTENER SCALE TO 1:1

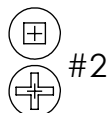

# 1

(A) x 1

(B) x 1

(G) x 4



**MAKE SURE TO FLUSH FRAME TO BACK CENTER STRINGER AS SHOWN.**

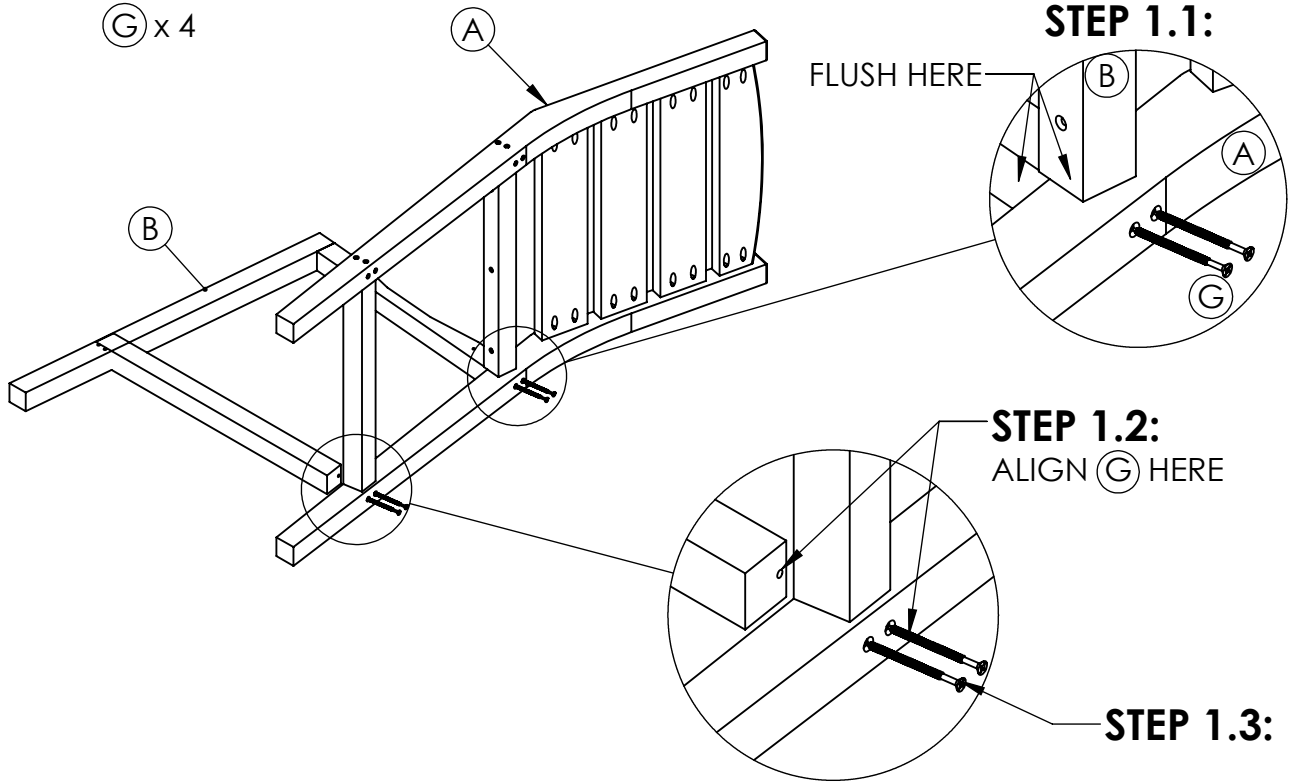

# 2

(C) x 1

(D) x 1

(G) x 4



**MAKE SURE TO FLUSH FRAME TO BACK CENTER STRINGER AS SHOWN.**

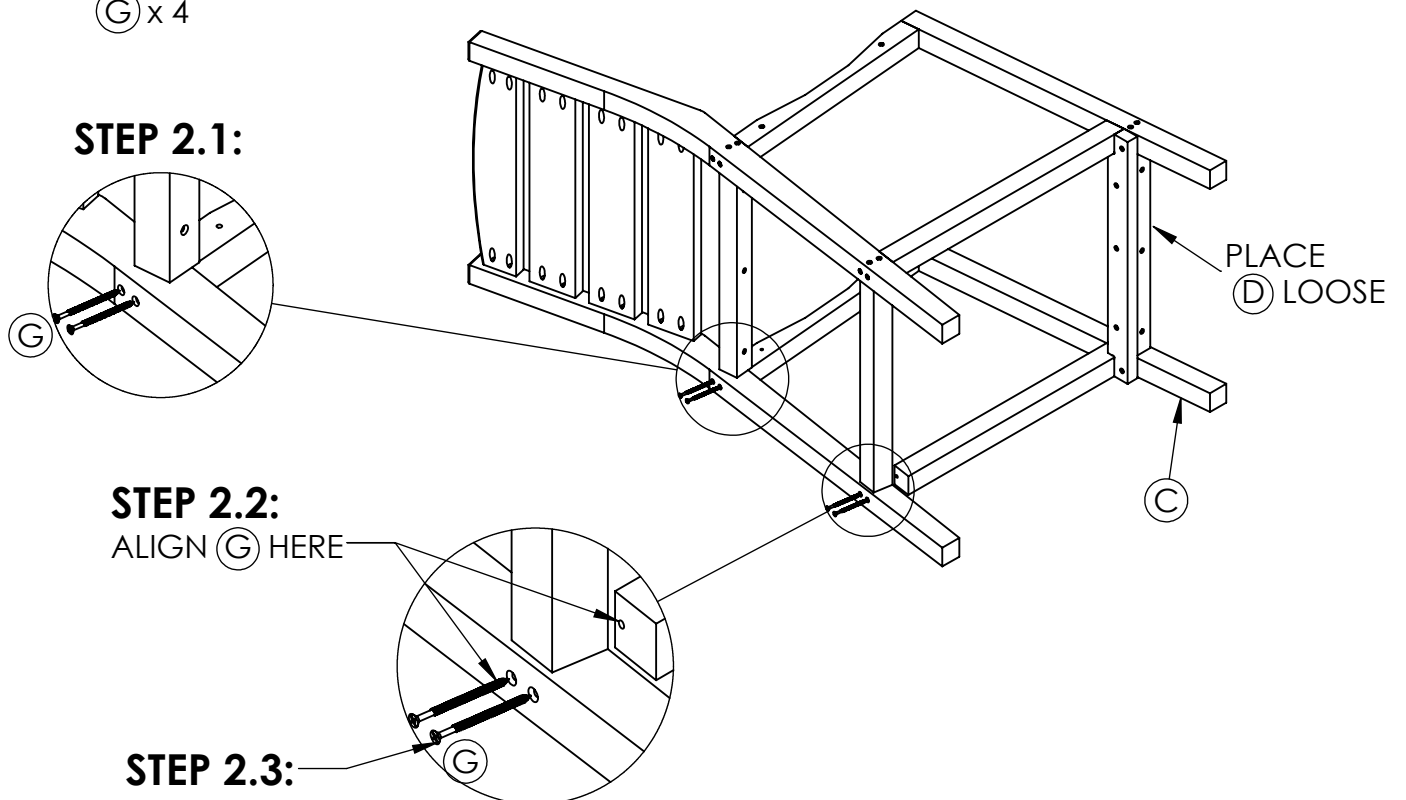

**3** ⓐ x 2

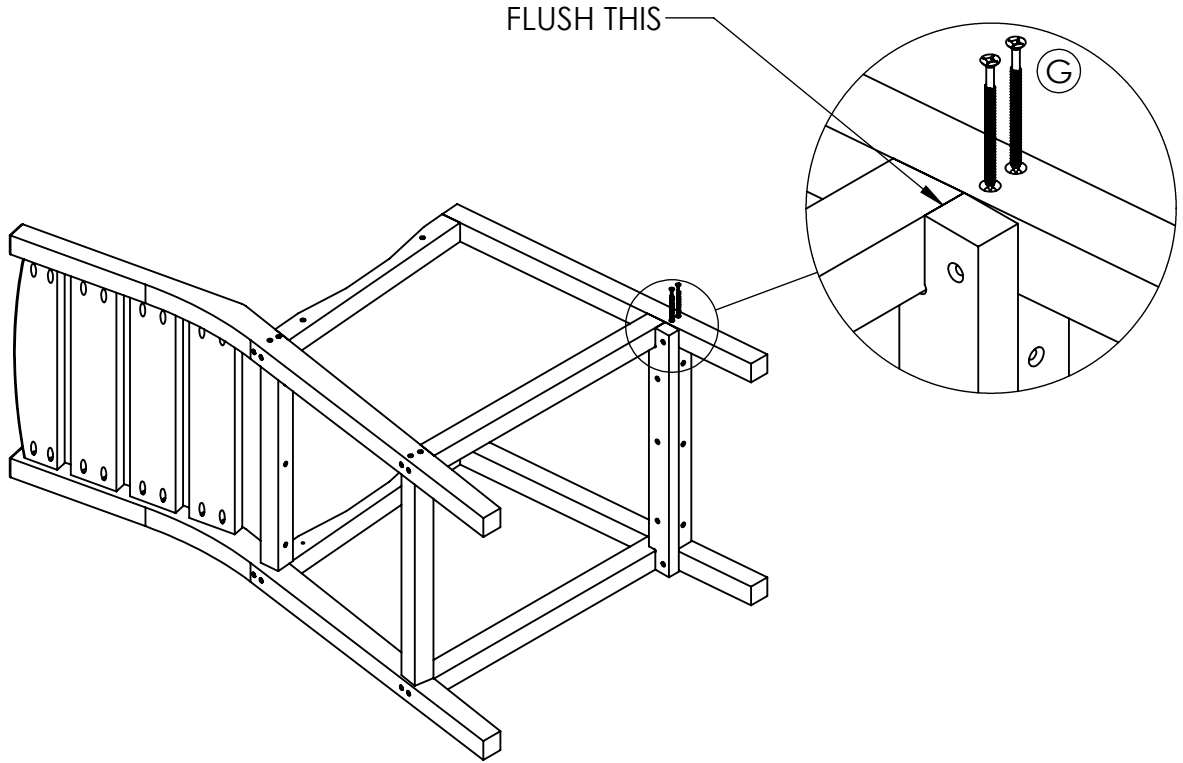

**4** ⓐ x 2

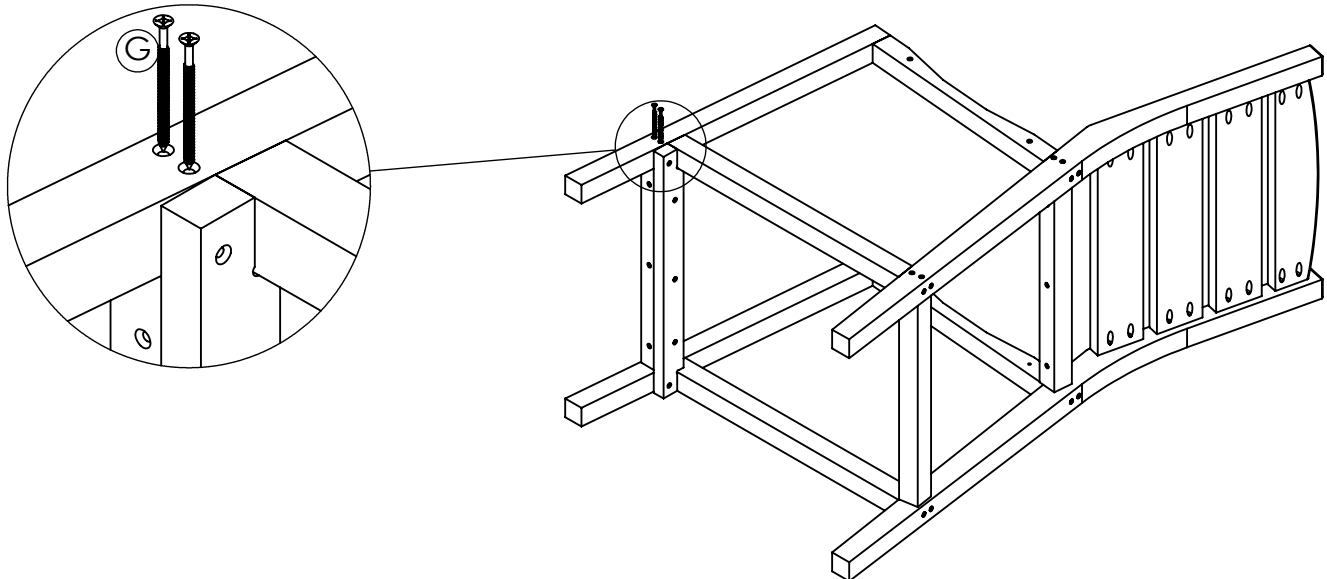

# 5

(E) x 1  
(H) x 3



(H)



**CHECK BEFORE USE**

SCREW SCALE 1:1

FLUSH THIS

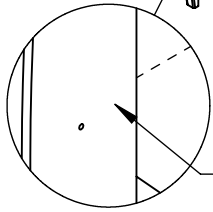
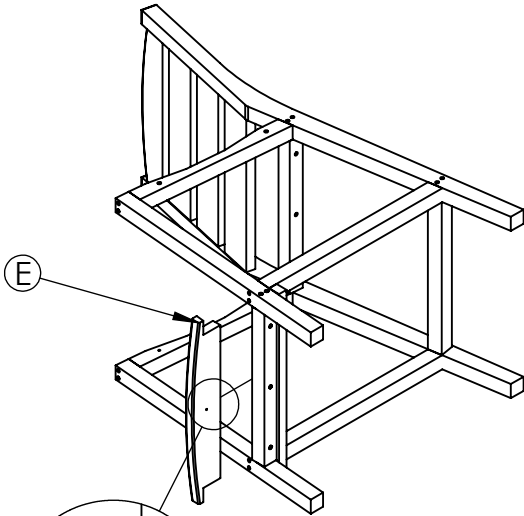
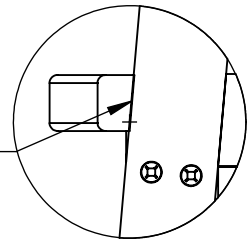

KEEP PECK MARK  
FACE DOWN

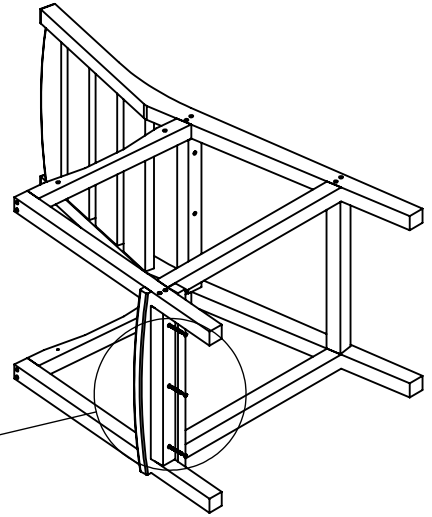
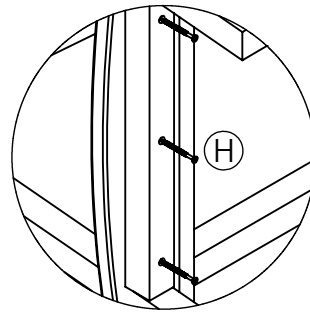

# 6

(H) x 2

**CHECK BEFORE USE**



(H)



SCREW SCALE 1:1

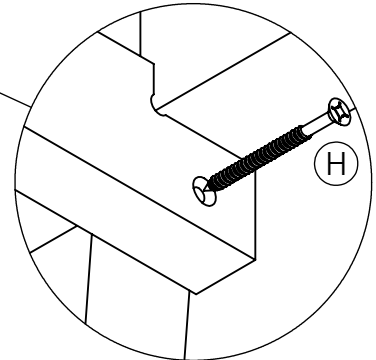
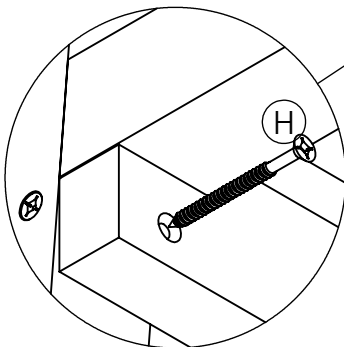
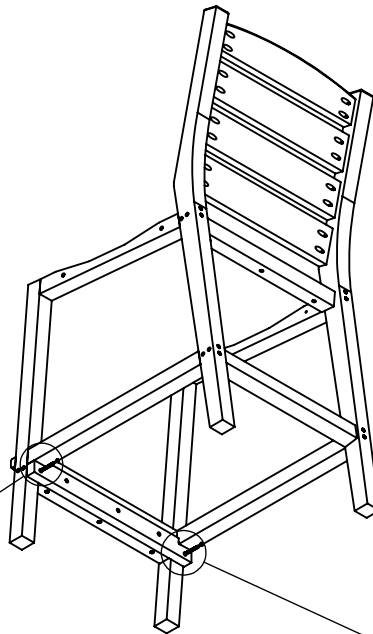

# 7

ⓕ x 1

ⓐ x 4

**STEP 7.1:**  
PUSH ⓕ DOWN AND FASTEN ⓐ

FLUSH THIS SURFACE

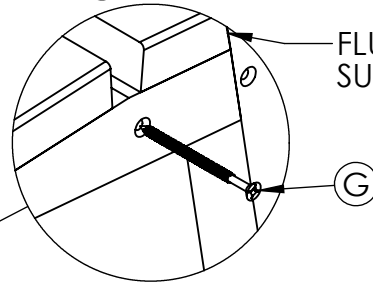
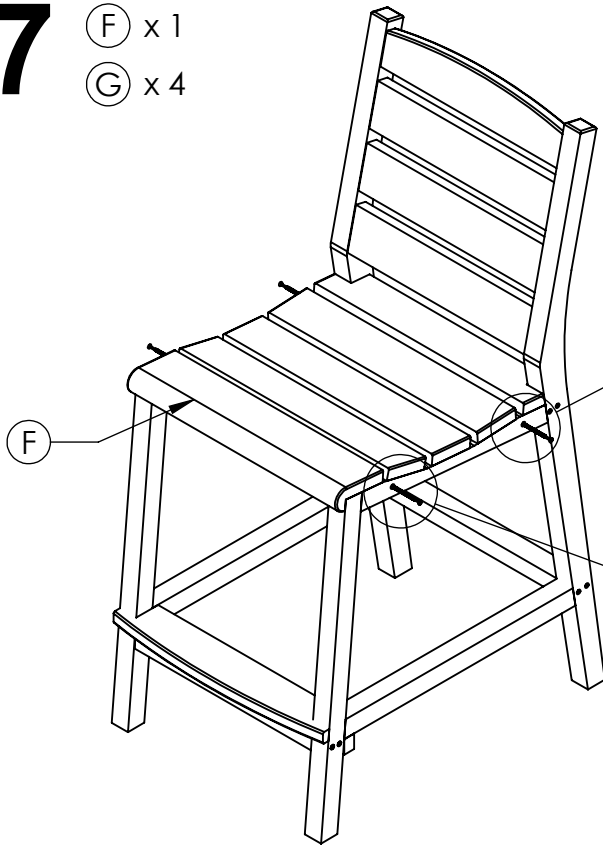

**STEP 7.2:**  
PUSH ⓕ DOWN AND FASTEN ⓐ

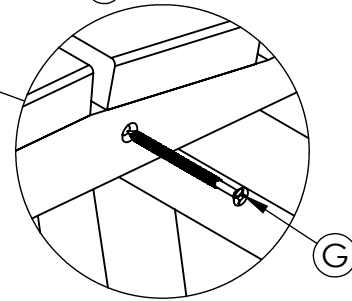

**NOTE: REPEAT SAME STEPS FOR OTHER SIDE.**

# 8

ⓓ x 3

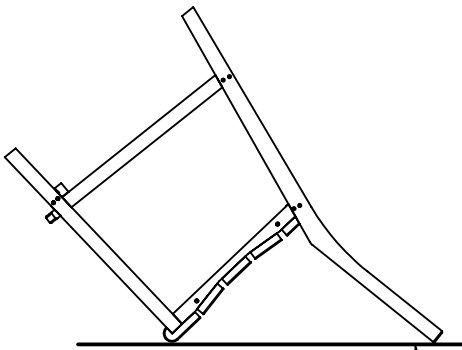

PLACE ON CLEAN/SMOOTH SURFACE TO AVOID SCRATCH

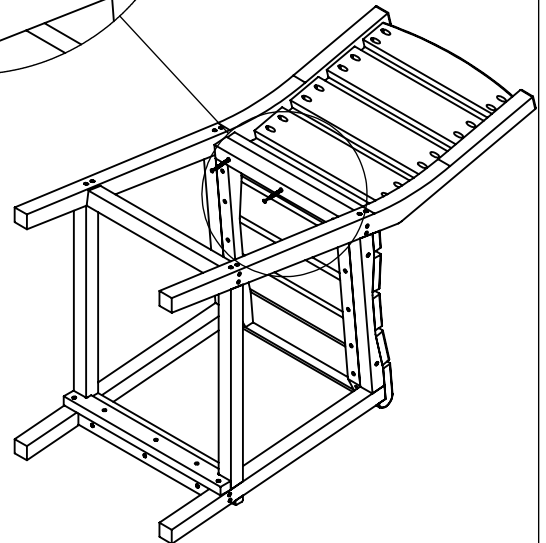
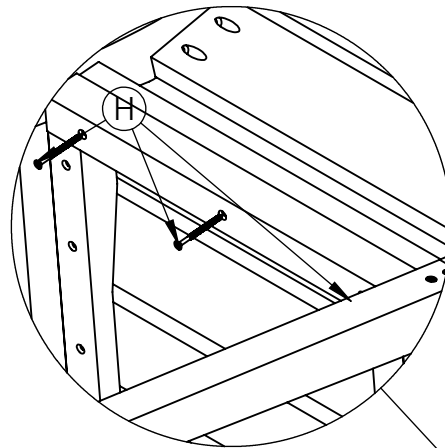

**CHECK BEFORE USE**

SCREW SCALE 1:1

