

**C.R. PLASTIC PRODUCTS**

*we create* sustainable outdoor living

FT01

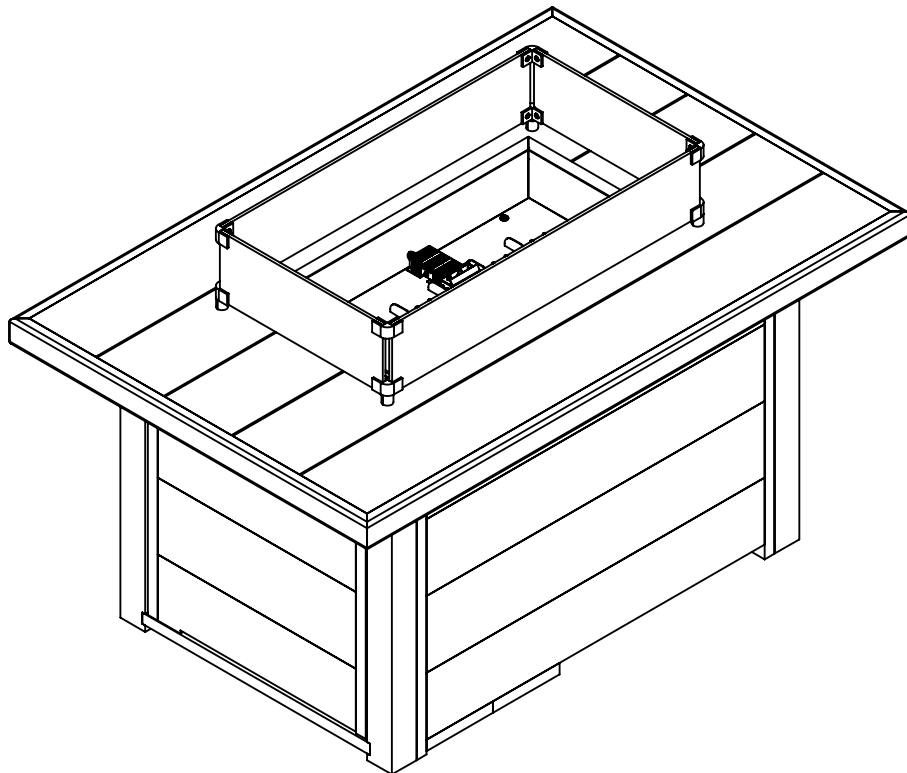

# C.R. PLASTIC PRODUCTS

*we create* sustainable outdoor living

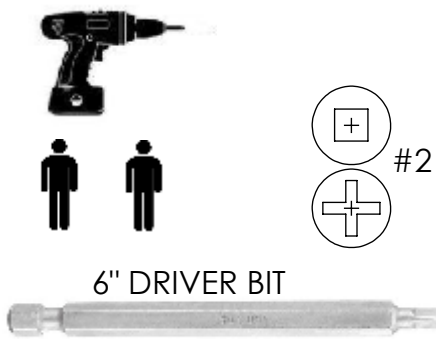
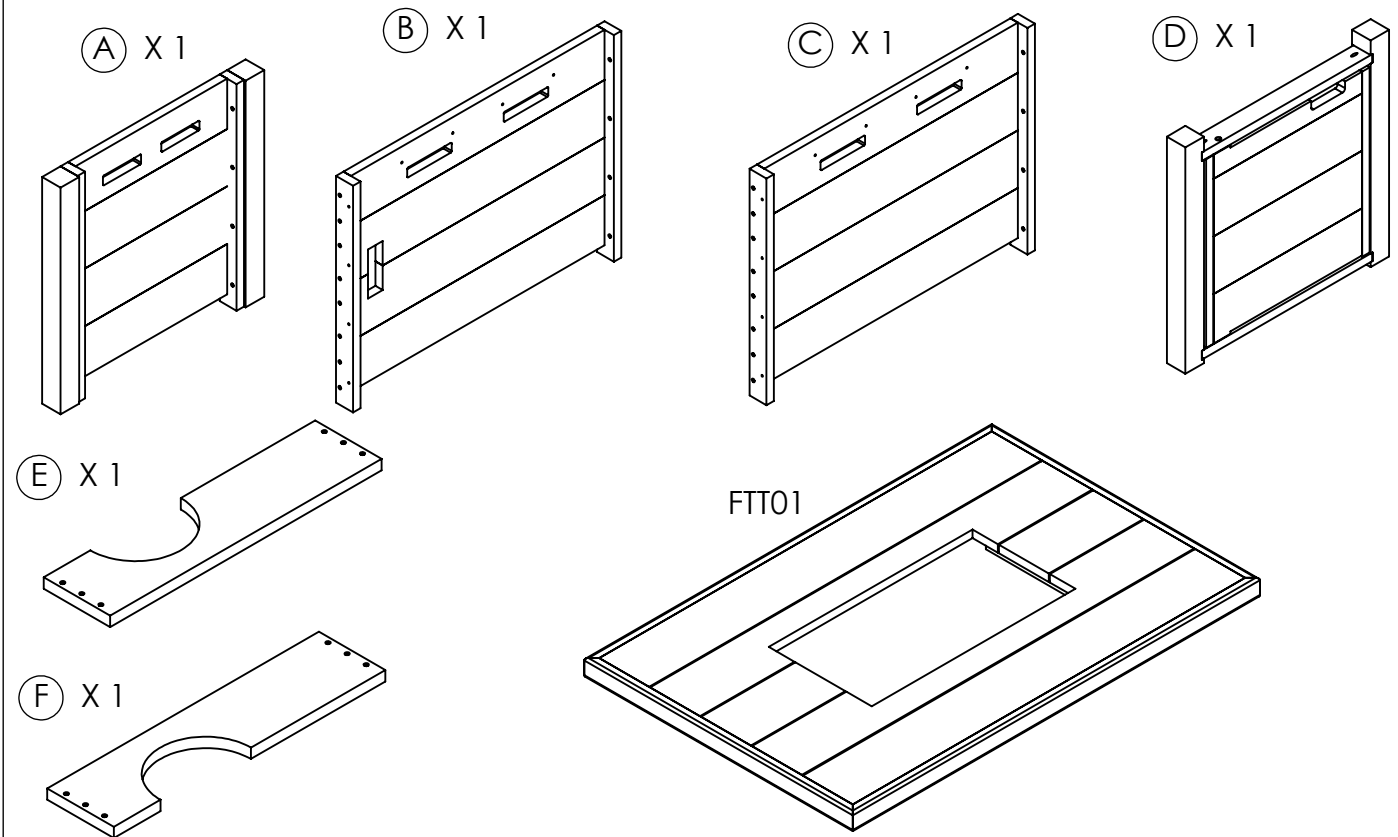

G X 44 1.5" / 38 mm  
4 SCREWS EXTRA



H X 4 0.75" / 19 mm



1-866-439-9521



wecare@crplastics.com



www.crpproducts.com

# 1

(A) X 1

(B) X 1

(G) X 4

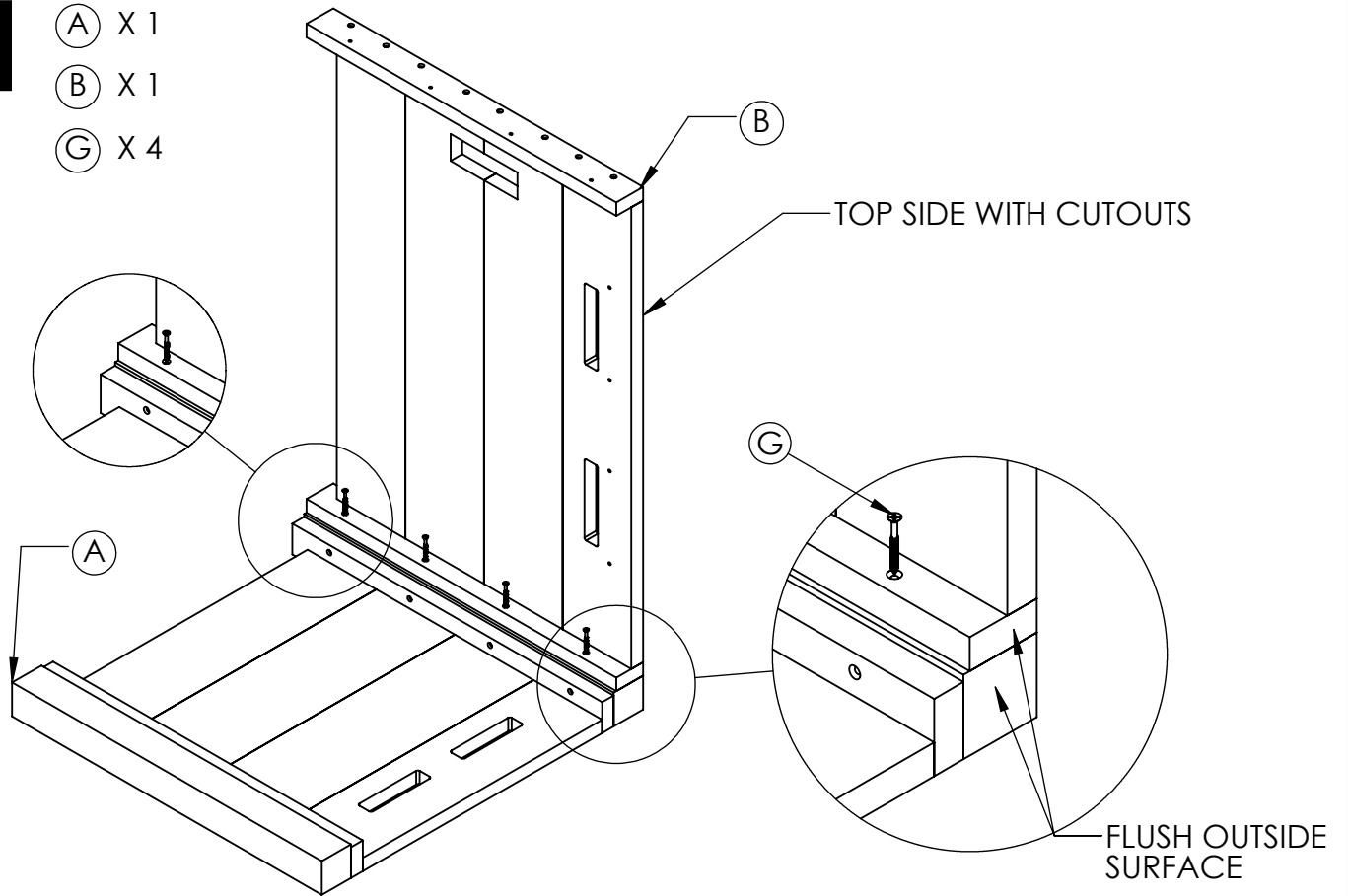

# 2

(C) X 1

(G) X 4

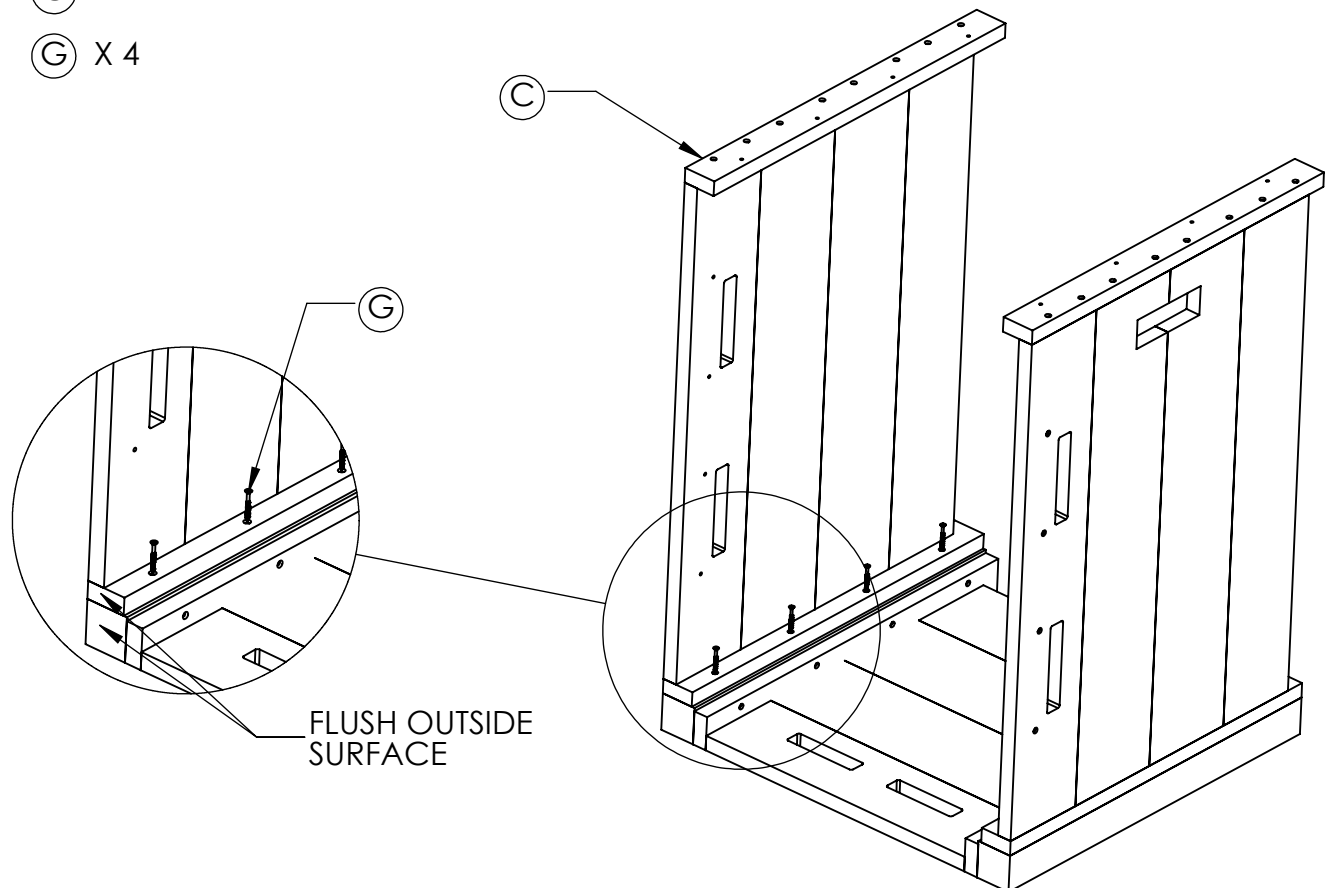

# 3

ⓓ X 1

ⓐ X 8

ⓐ X 4 HIDDEN SCREWS  
THIS SIDE

FLUSH OUTSIDE  
SURFACE

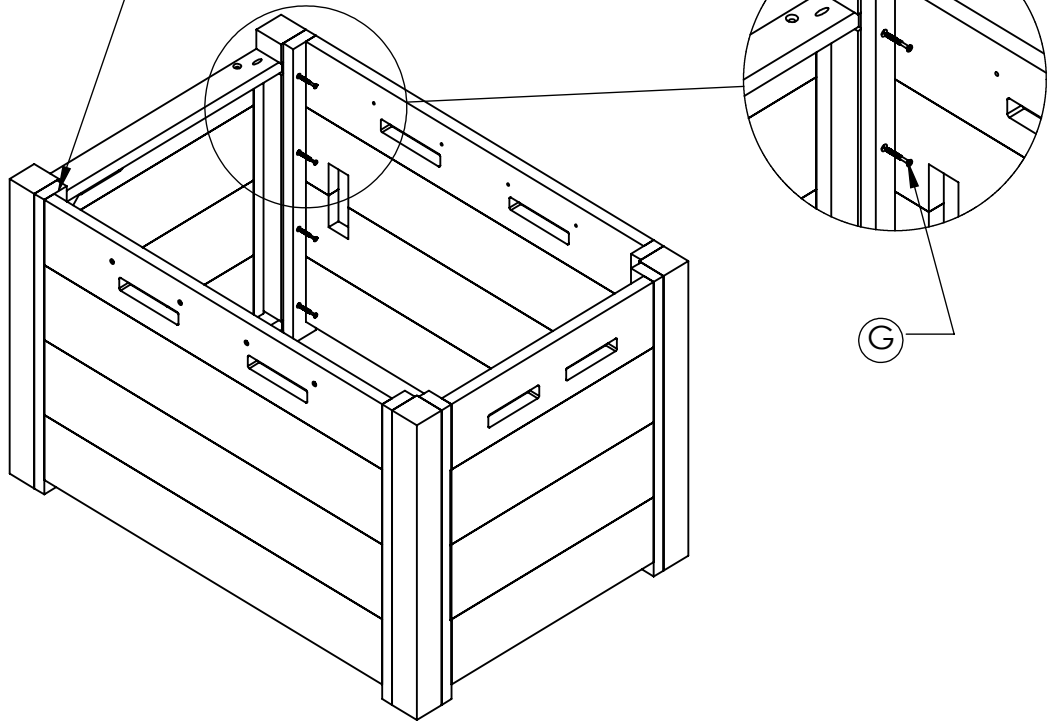

# 4

ⓓ X 4

CONTROL PANEL X 1

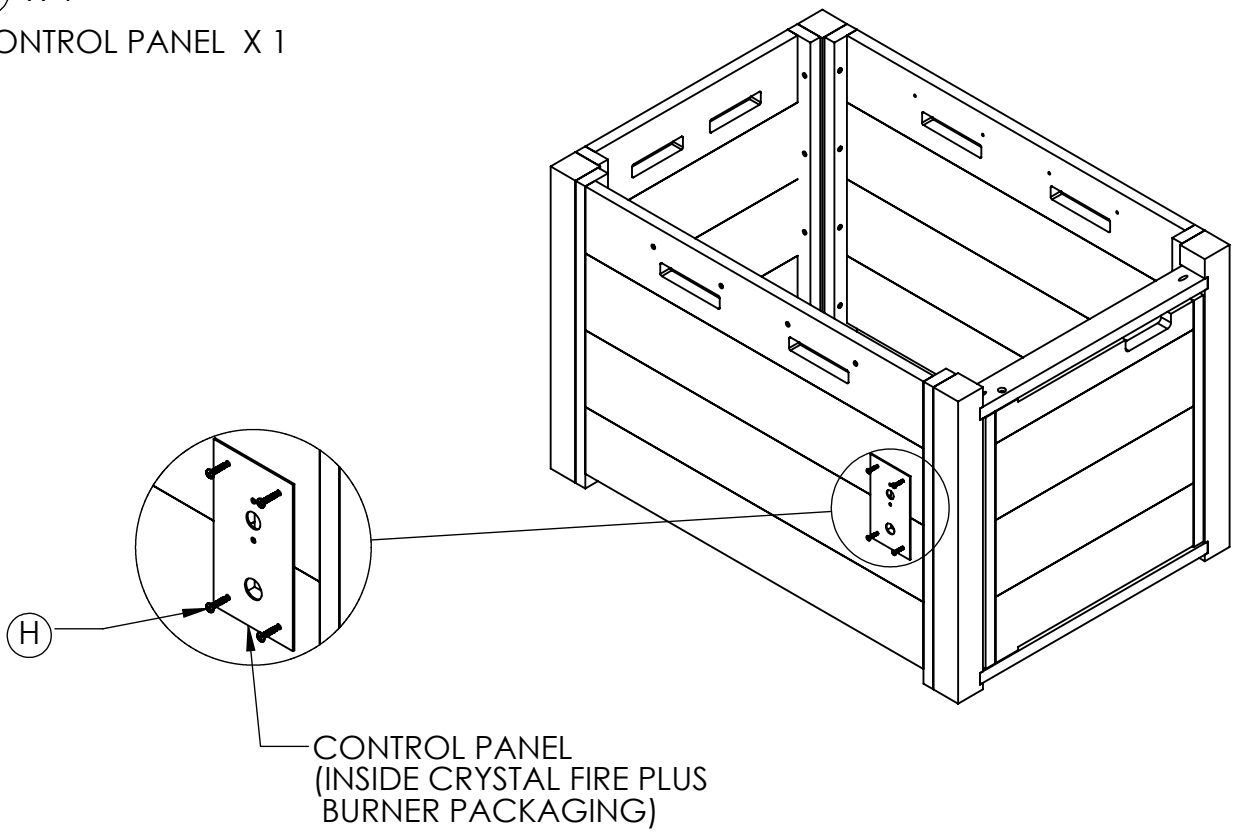

# 5

(E) X 1

(G) X 6

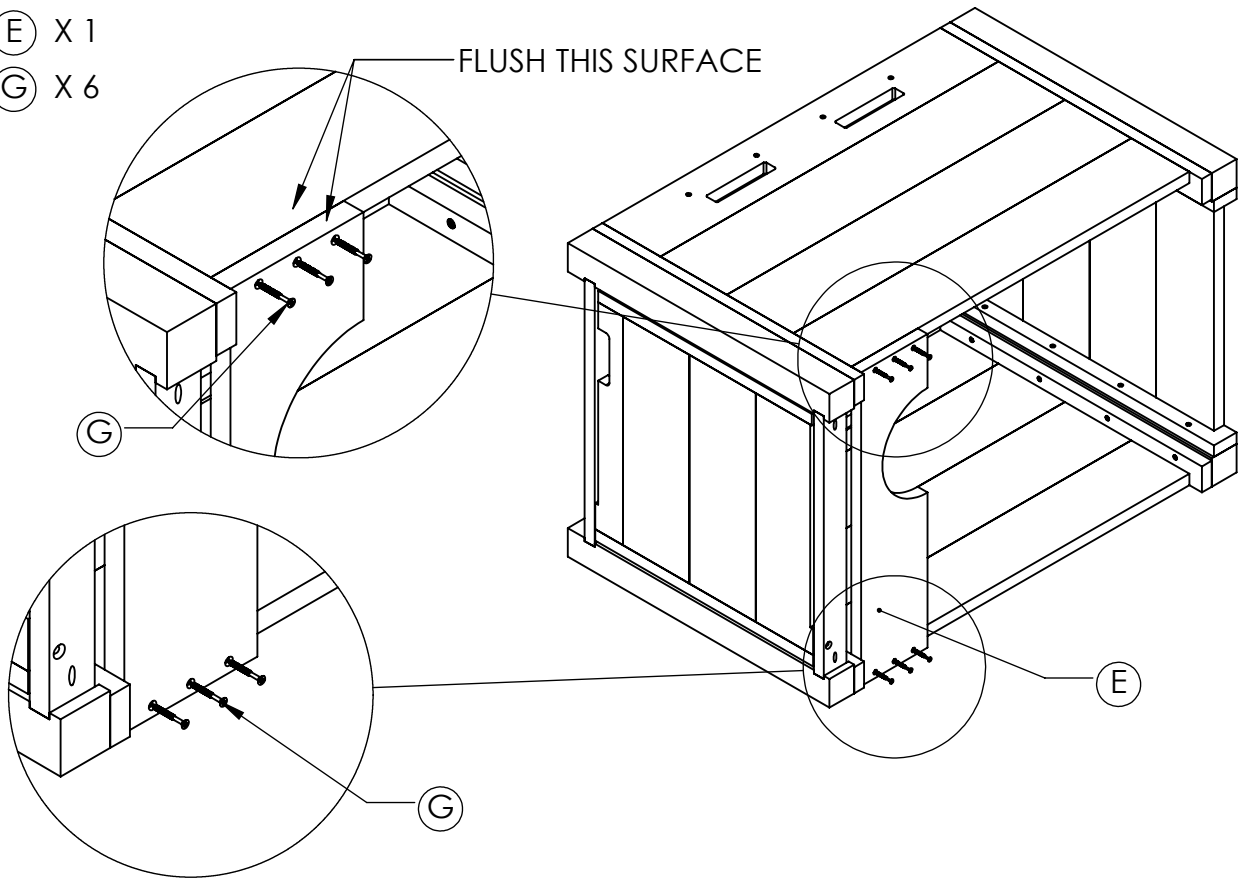

# 6

(F) X 1

(G) X 6

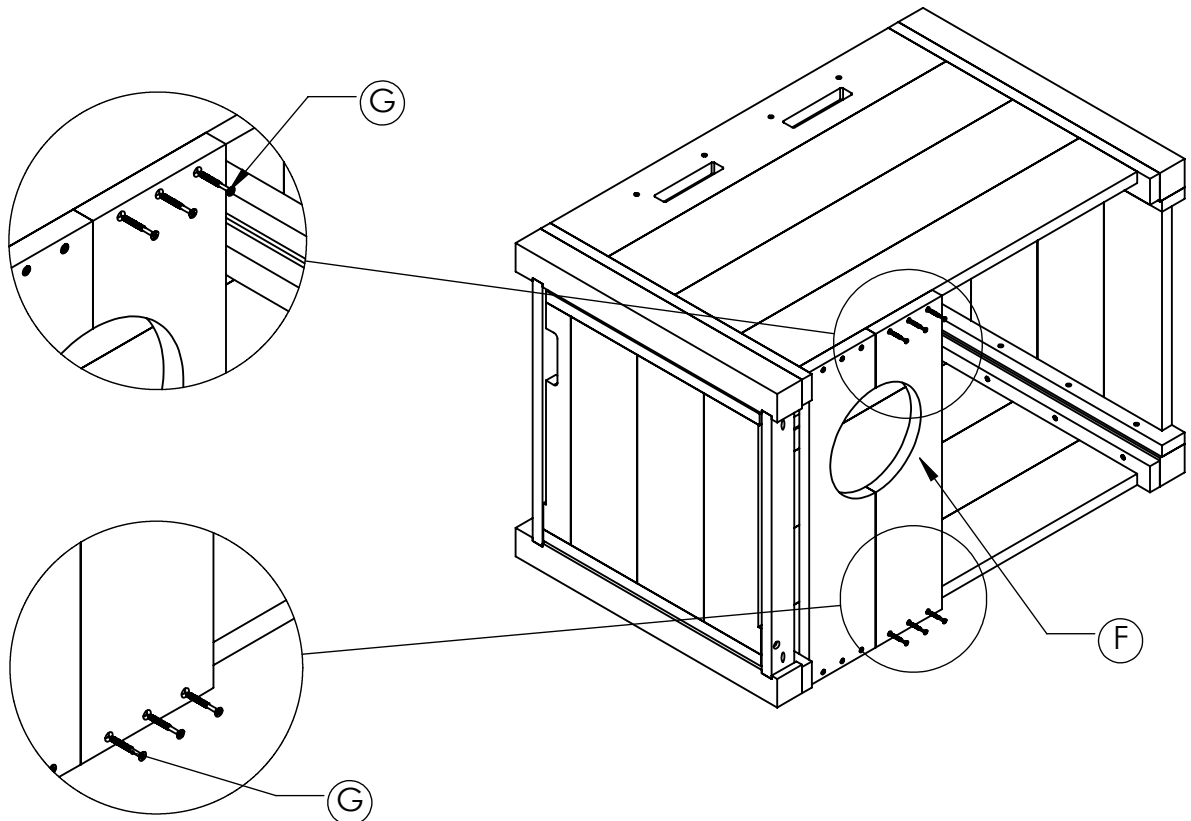

**7** FTT01 X 1  
Ⓞ X 12

NOTE: Ⓞ X 4 OTHER SIDE AS WELL.



USE 6" DRIVER BIT

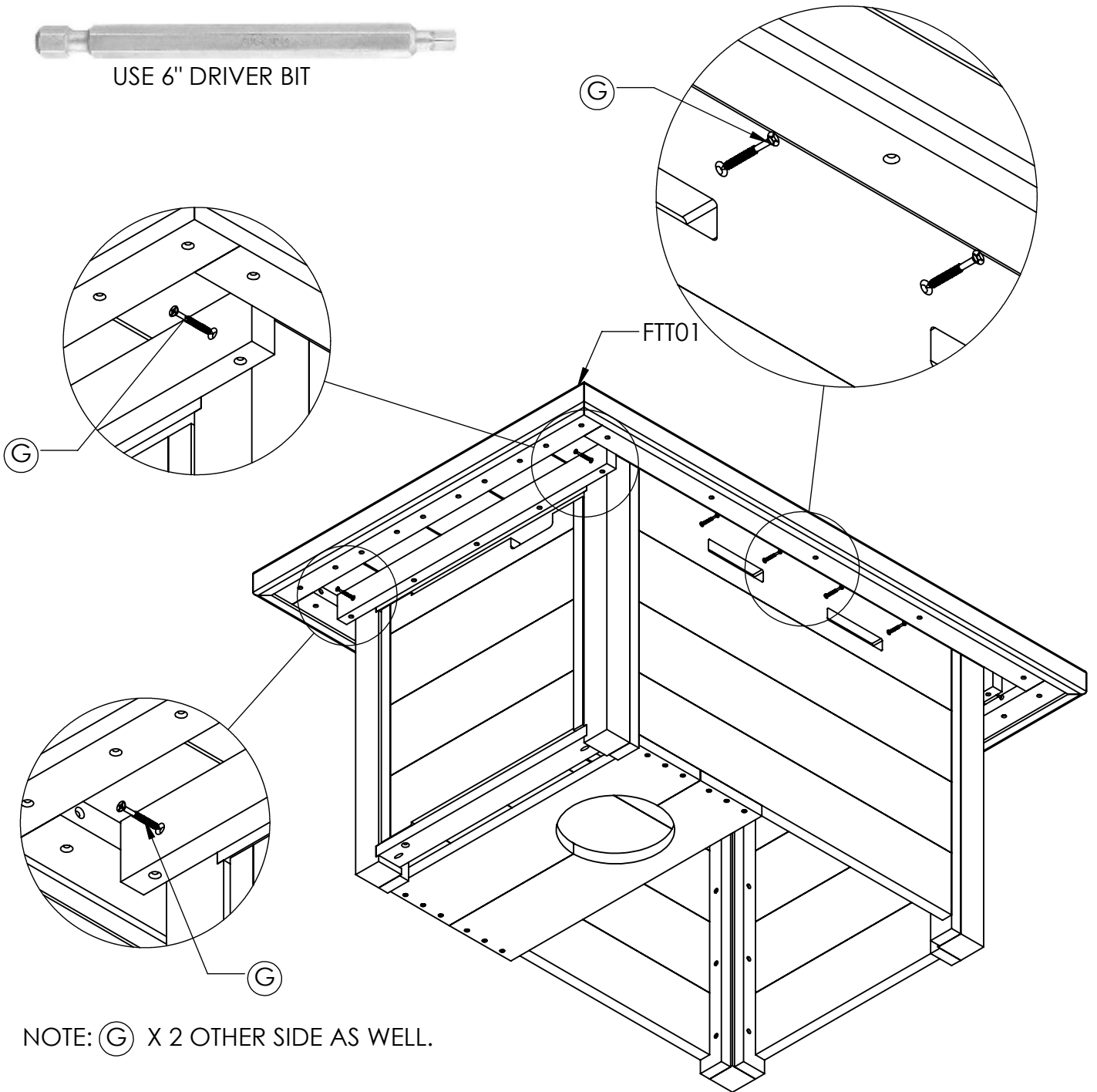

NOTE: Ⓞ X 2 OTHER SIDE AS WELL.

8

NOTE: SEE CRYSTAL FILE PLUS MANUAL FOR BURNER ASSEMBLY AND INSTALLATION.

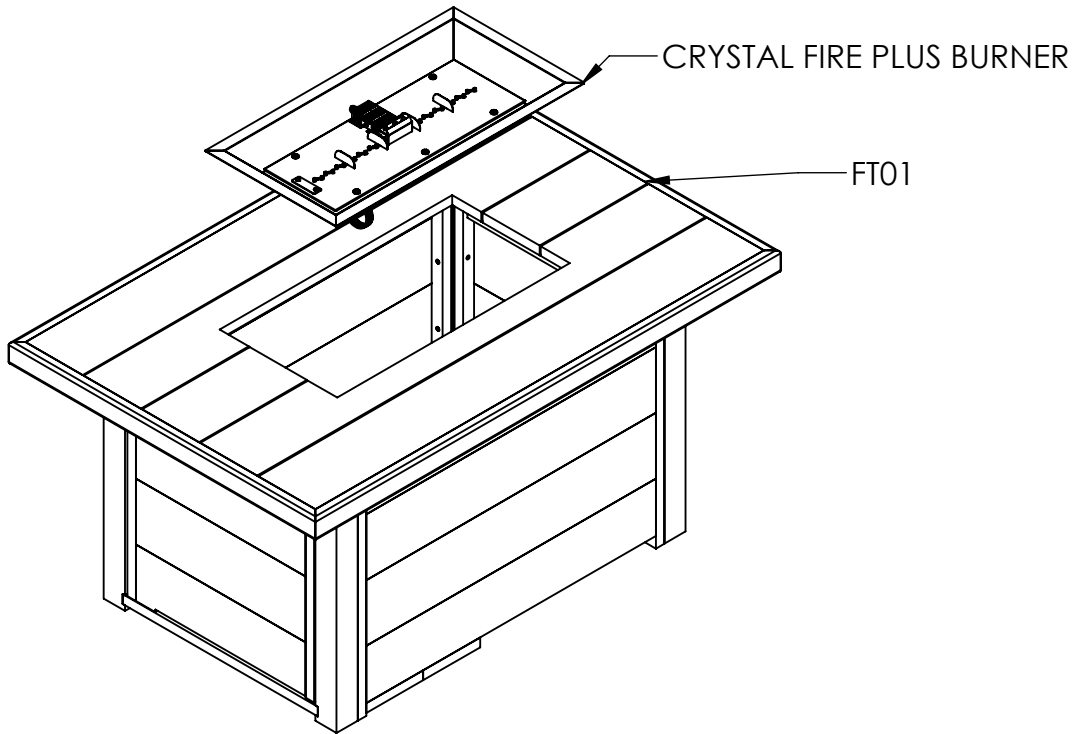

9

NOTE: SEE GLASS GUARD ASSEMBLY INSTRUCTION.

**IMPORTANT:  
GLASS GUARD REQUIRED.**

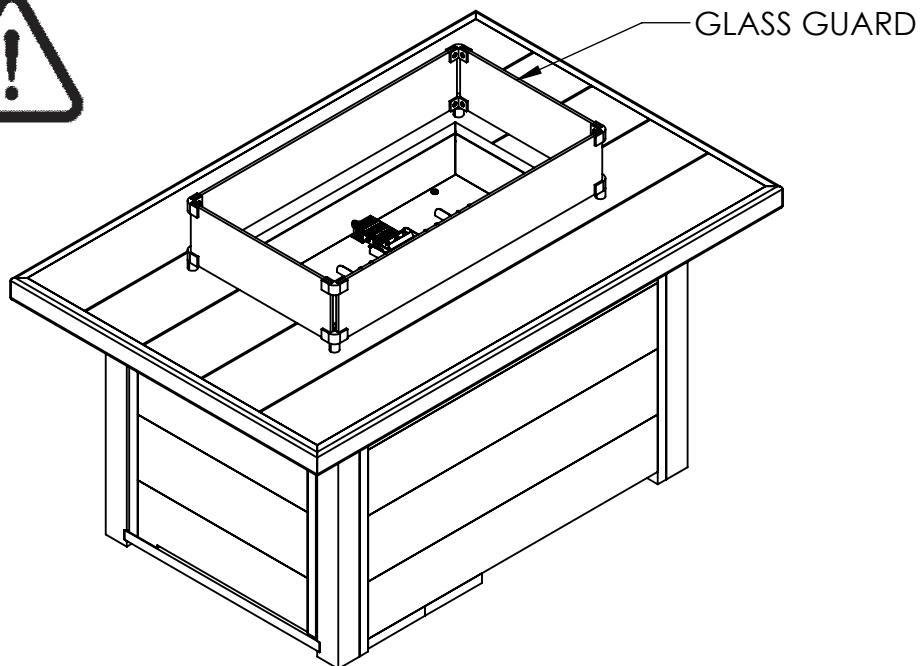

# 10

NOTE: SEE CRYSTAL FILE BURNER QUICK START GUIDE WITH PROPANE CYLINDER OR NATURAL GAS CONVERSION.

