

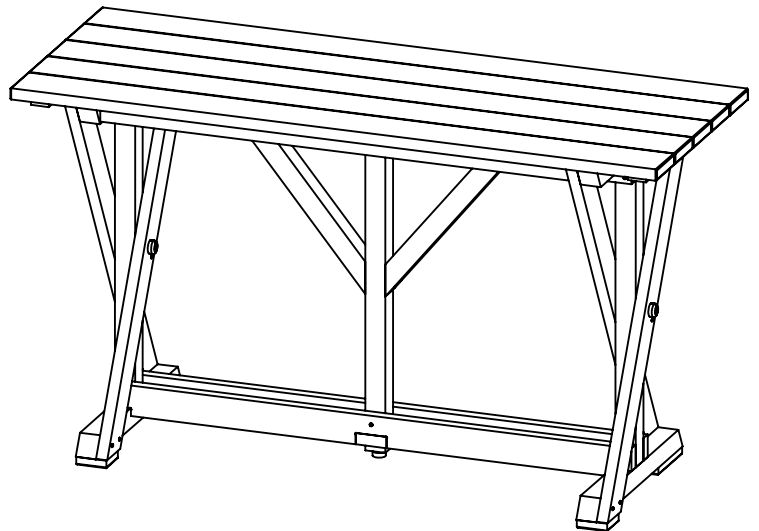

*we create* sustainable outdoor living

# T204

## Harvest Bar Table



BOX#1-TT204  
 BOX#2-TS204  
 BOX#3-TB204

TT204 BOX INCLUDES:

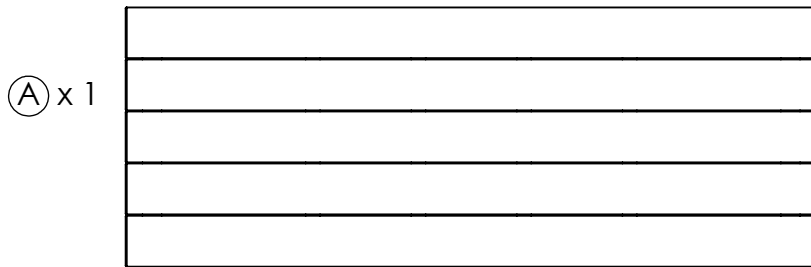

TS204 BOX INCLUDES:

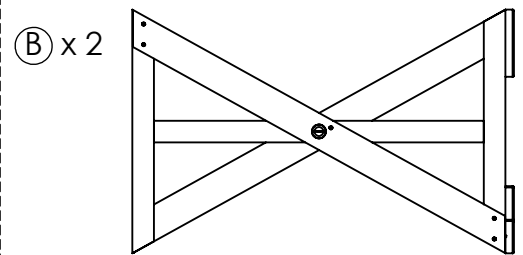

TB204 BOX INCLUDES:

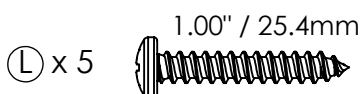
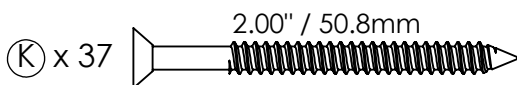
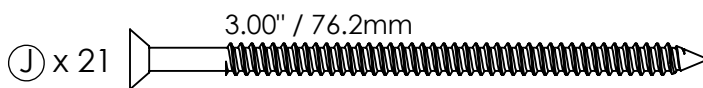
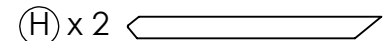
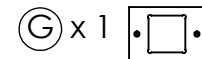
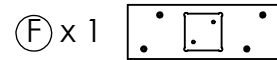
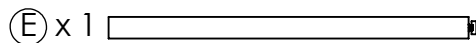
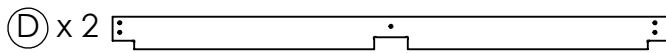
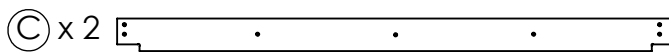

FASTENER SCALE TO 1:1



#2



[www.crpproducts.com](http://www.crpproducts.com)

1

(A) x 1

(B) x 2

(J) x 20



CHECK THE SCREW SCALE 1:1 BEFORE USE

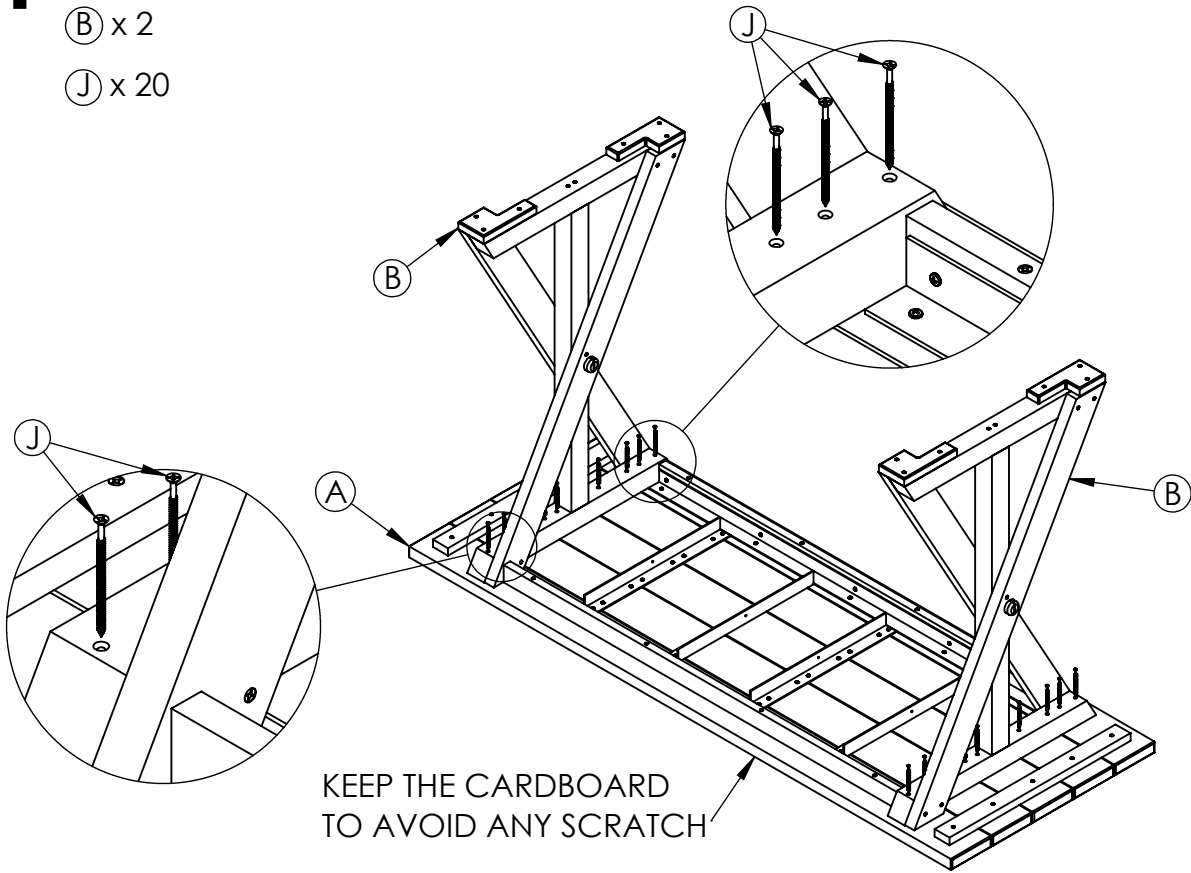

2

(C) x 1

(D) x 1

(K) x 8

KEEP CUTOUT OF (D)  
FACING UPWARD.

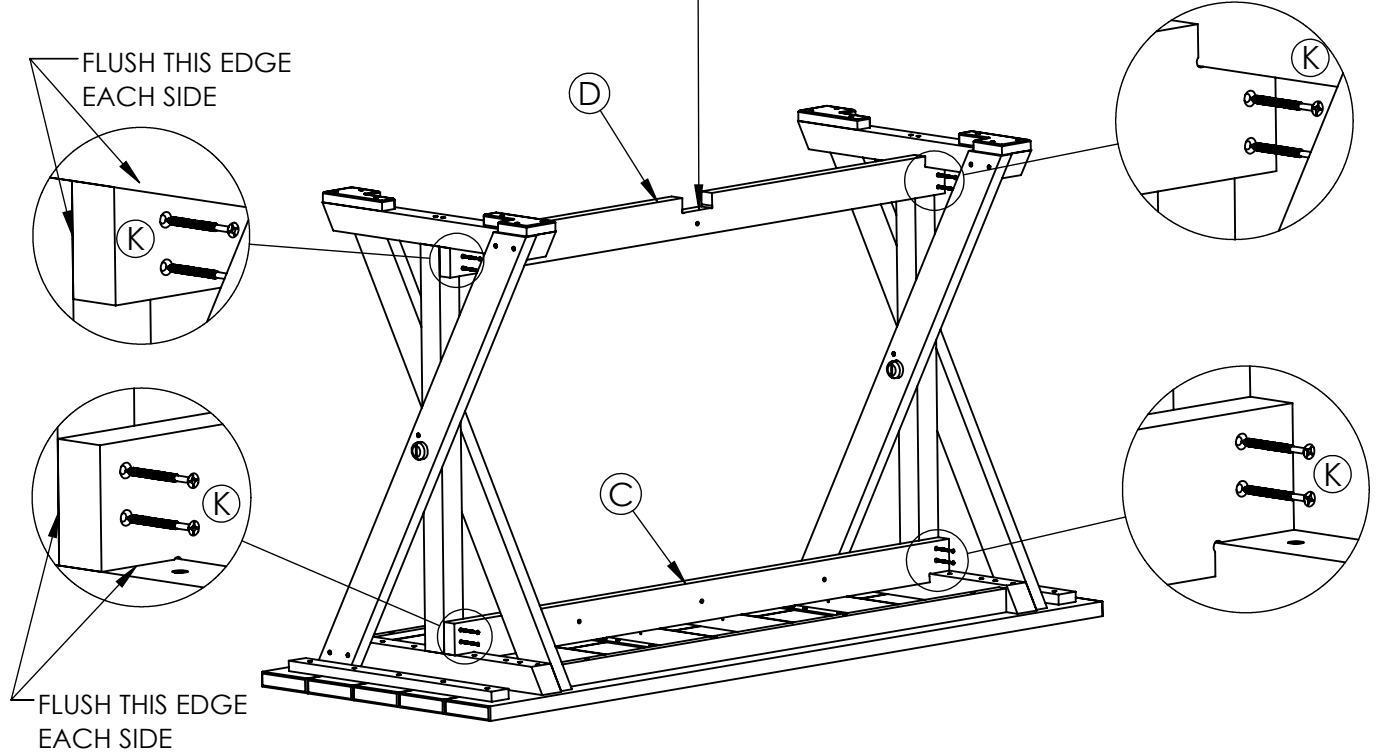

# 3

- ⓔ x 1
- ⓕ x 1
- Ⓚ x 2

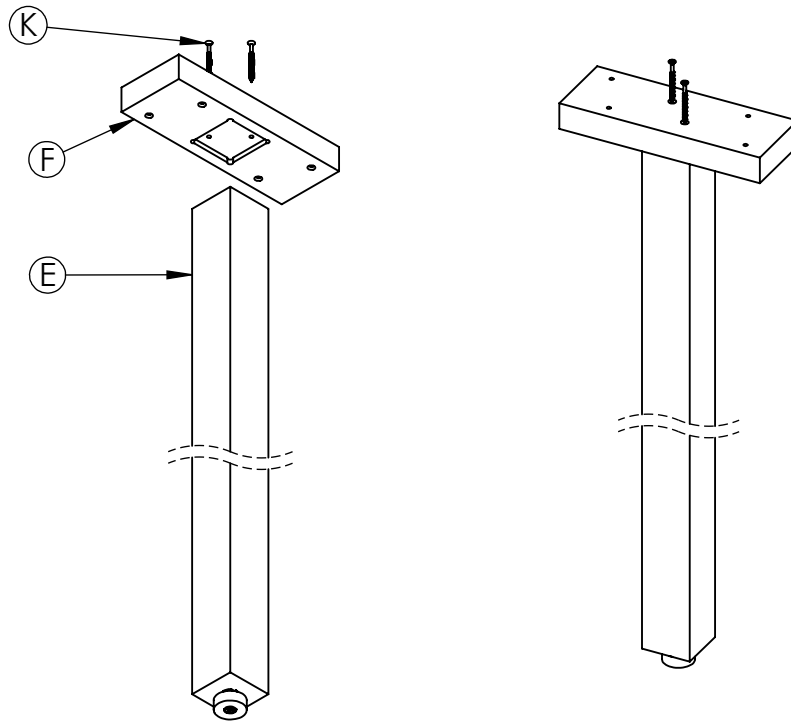

# 4

- Ⓚ x 4
- Ⓛ x 2



**CHECK THE SCREW SCALE 1:1 BEFORE USE**

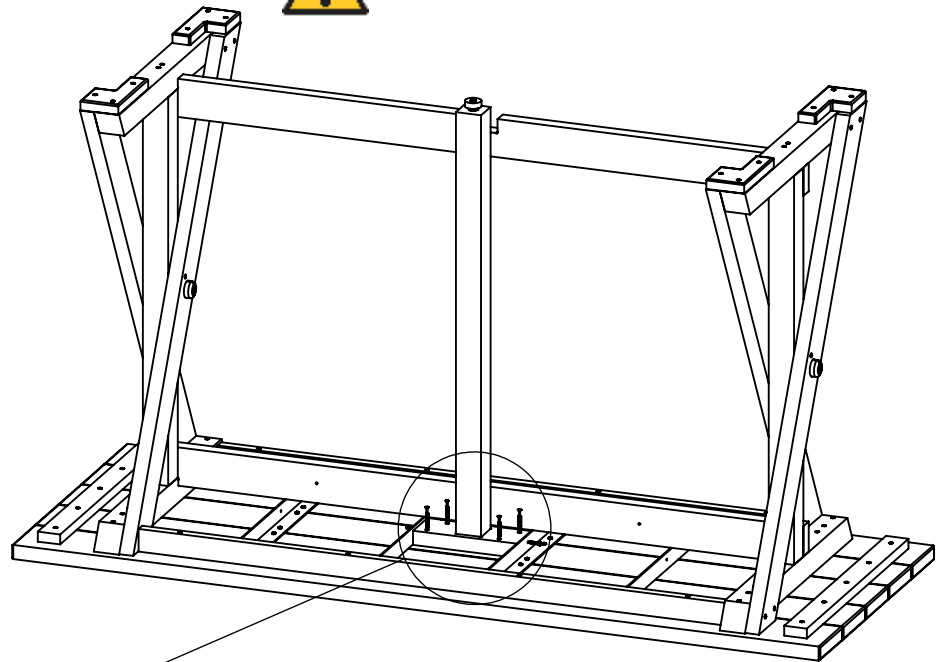

FLUSH THIS EDGE

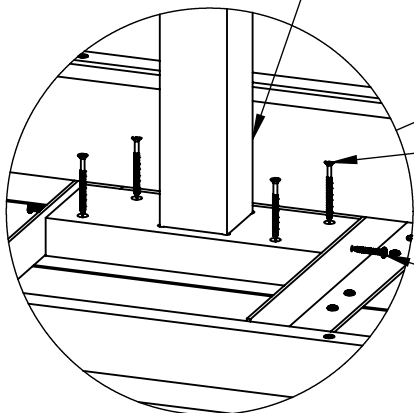

Ⓚ x 4  
**STEP 4.1**

Ⓛ x 2  
**STEP 4.2**

# 5

ⓐ x 1

Ⓚ x 3

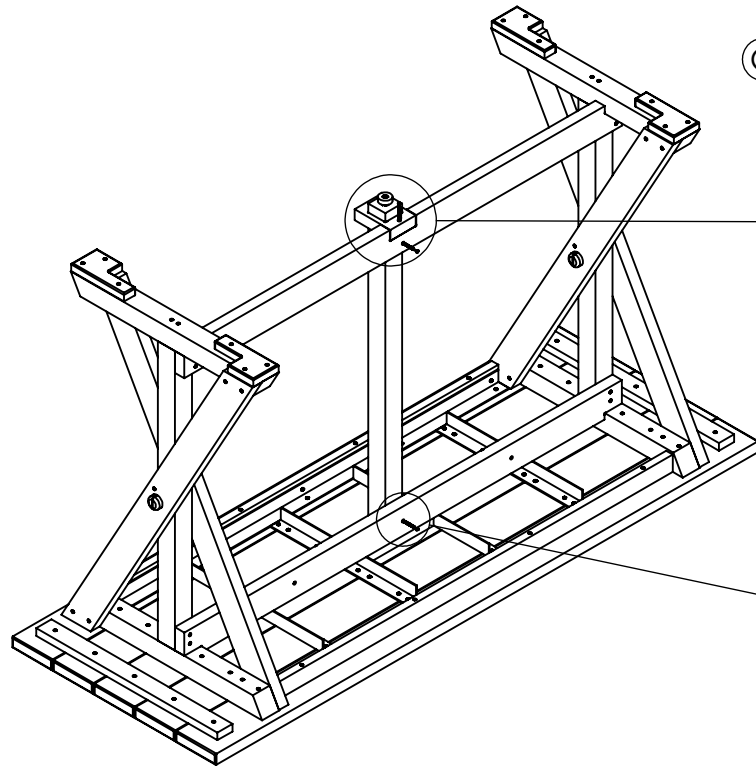

**STEP 5.1**

FLUSH THIS EDGE

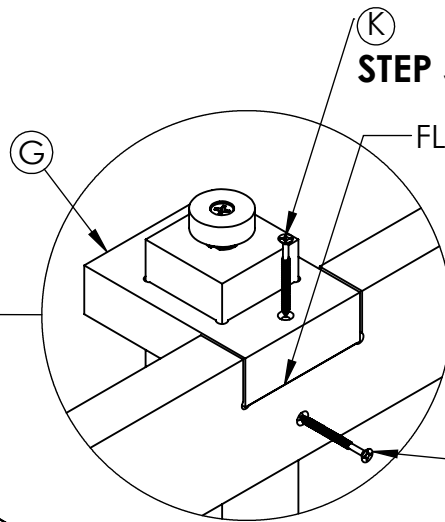

**STEP 5.2**

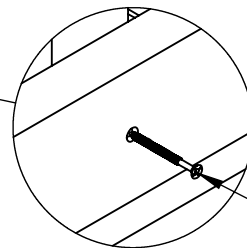

**STEP 5.2**

# 6

ⓓ x 2

Ⓚ x 4

Ⓛ x 2

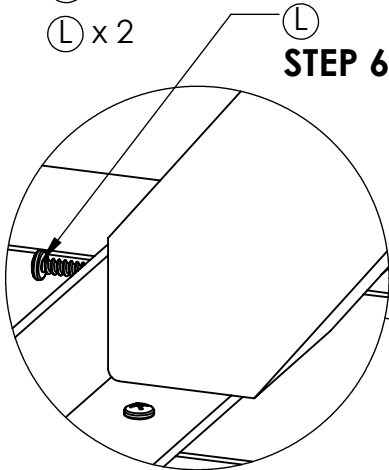

**STEP 6.1**

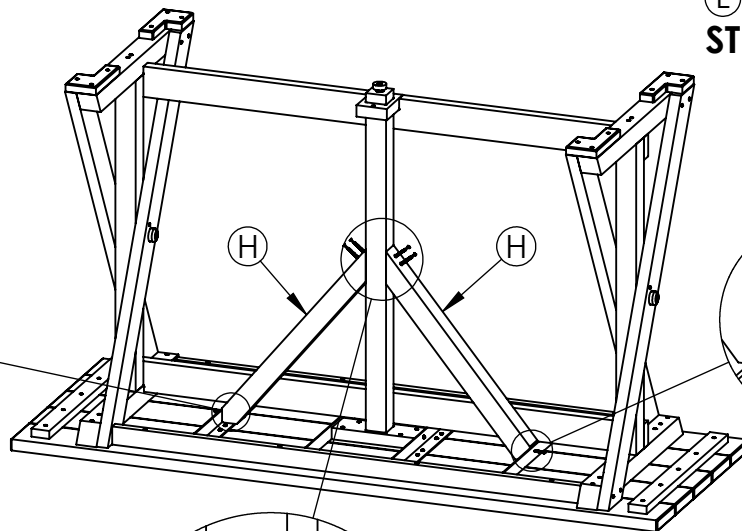

Ⓛ

**STEP 6.1**

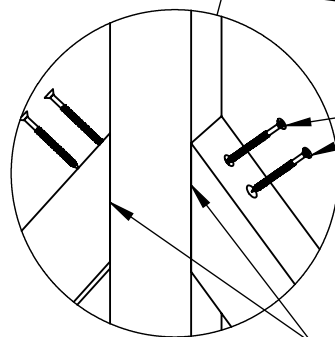
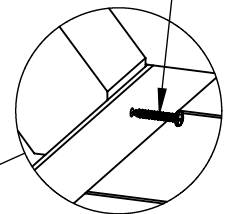

Ⓚ x 4

**STEP 6.2**

FLUSH THIS EDGE

# 7

Ⓒ x 1

Ⓓ x 1

Ⓚ x 9

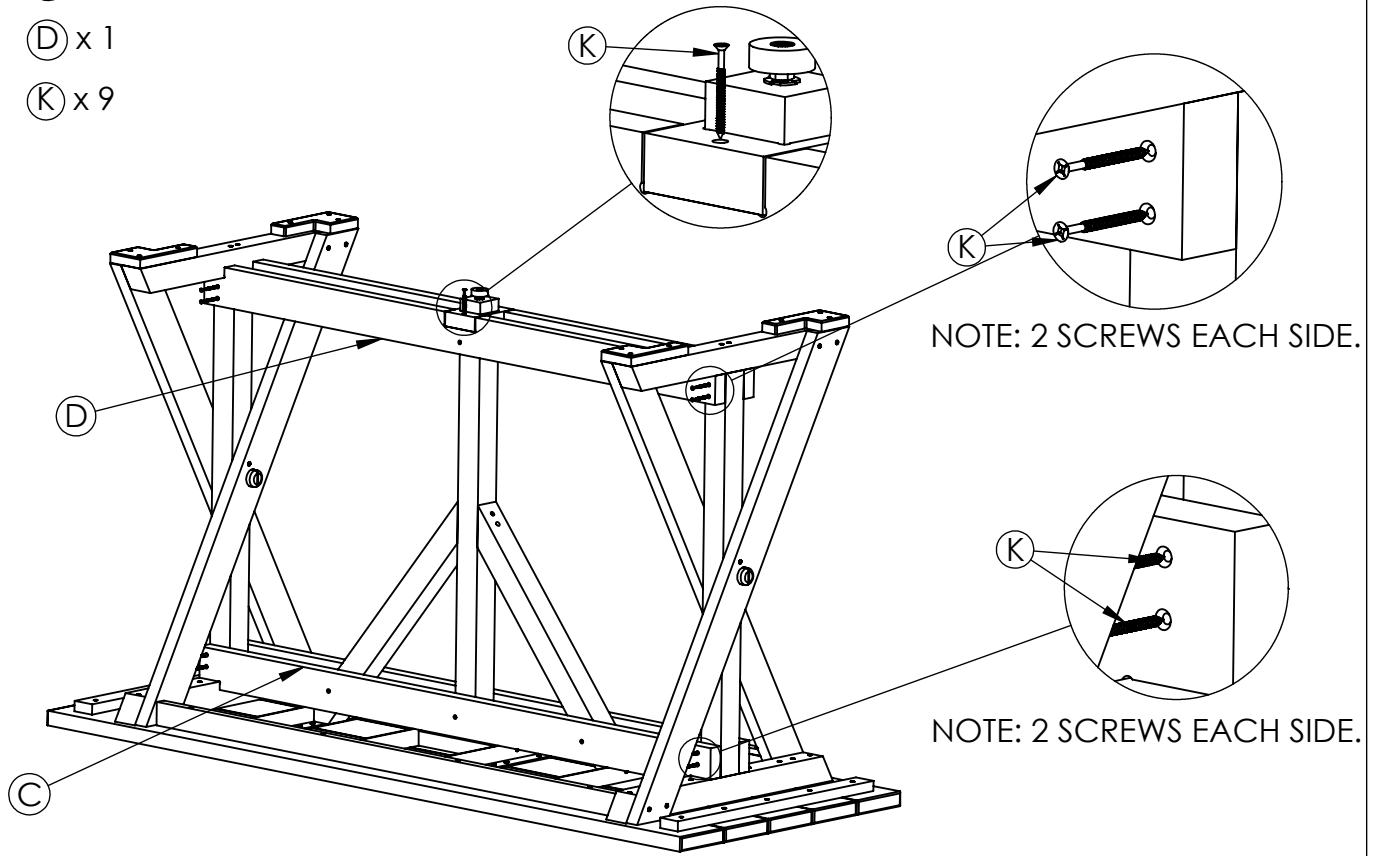

# 8

Ⓚ x 6

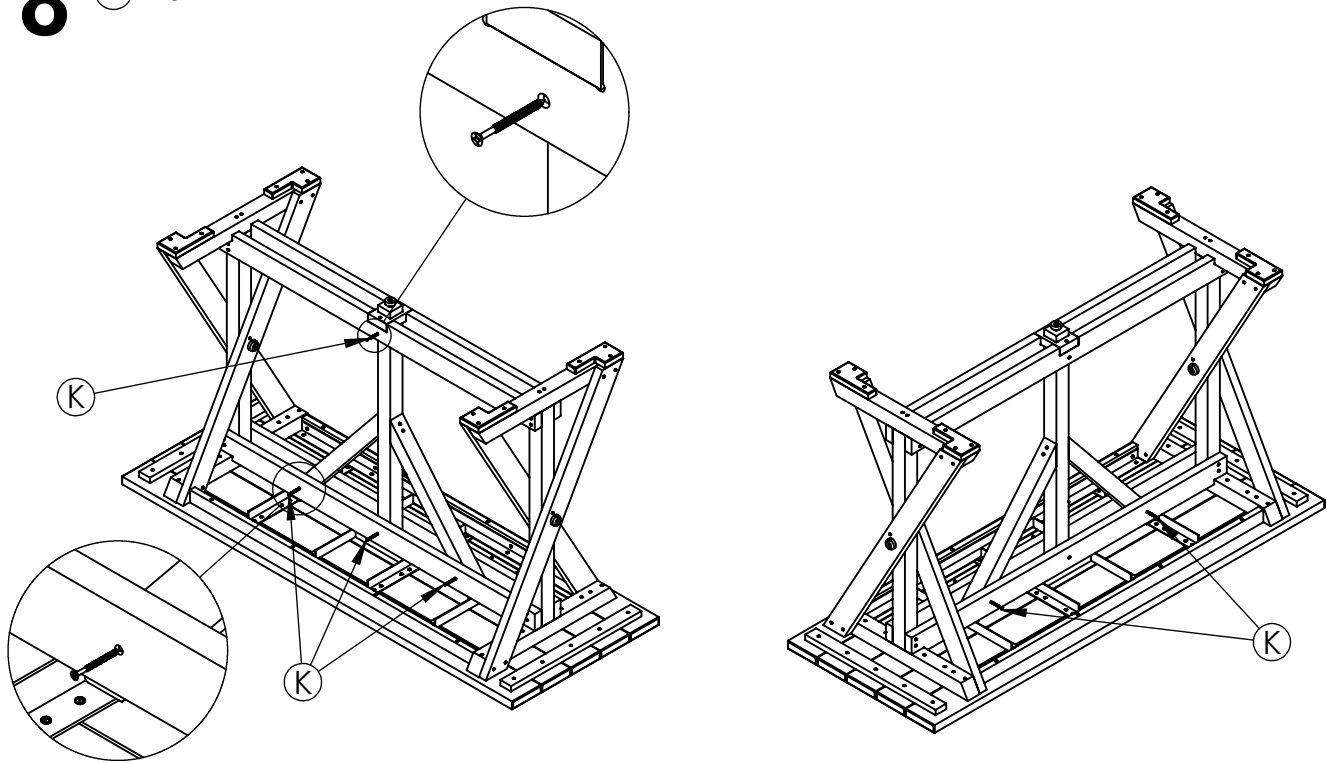

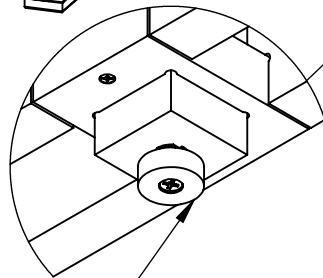
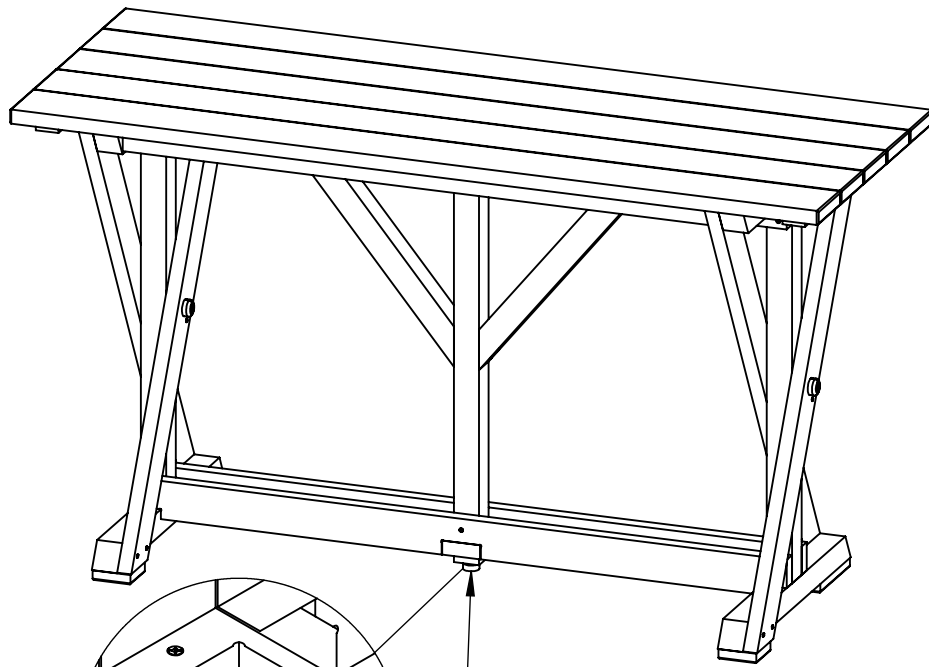
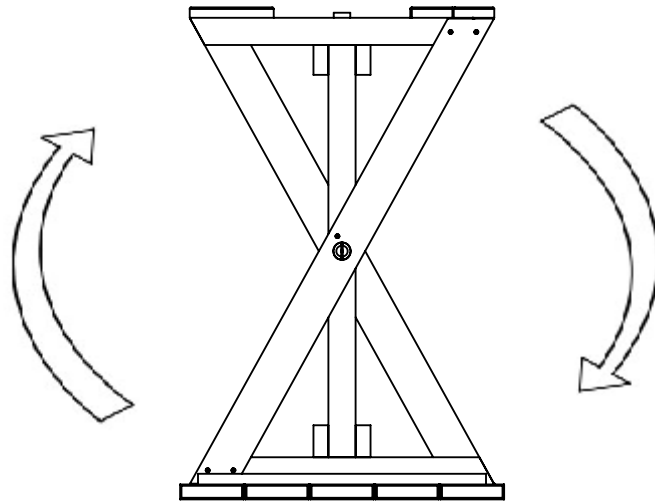

**LOWER TO SURFACE  
ONCE COMPLETE.**



**NOTE:**  
USE LEVELER TO LEVEL THE TABLE  
ON UNEVEN FLOORING.



ⓐ, ⓑ, ⓓ - ONE EXTRA FASTENER